



JSC "AVK"

MOSCOW, JANUARY 2025



General information

- The main activity of the company AVK is the development, production, and sale of industrial and special chemical products.
- AVK started its operations in 2009 and since then has been creating solutions for refining, chemical, and petrochemical industries for 15 years, leveraging its extensive and distinctive expertise.
- Today, the AVK Group has representative offices and production sites in 9 countries (Russia, Belarus, Kazakhstan, Kyrgyzstan, Lithuania, Austria, China, Turkey, UAE).
- The quality management system of AVK is certified according to the state standard ISO 9001:2015
- The company's revenue for 2023 was 17 billion.

Main areas of activity



Engineering Research Center of JSC «AVK»

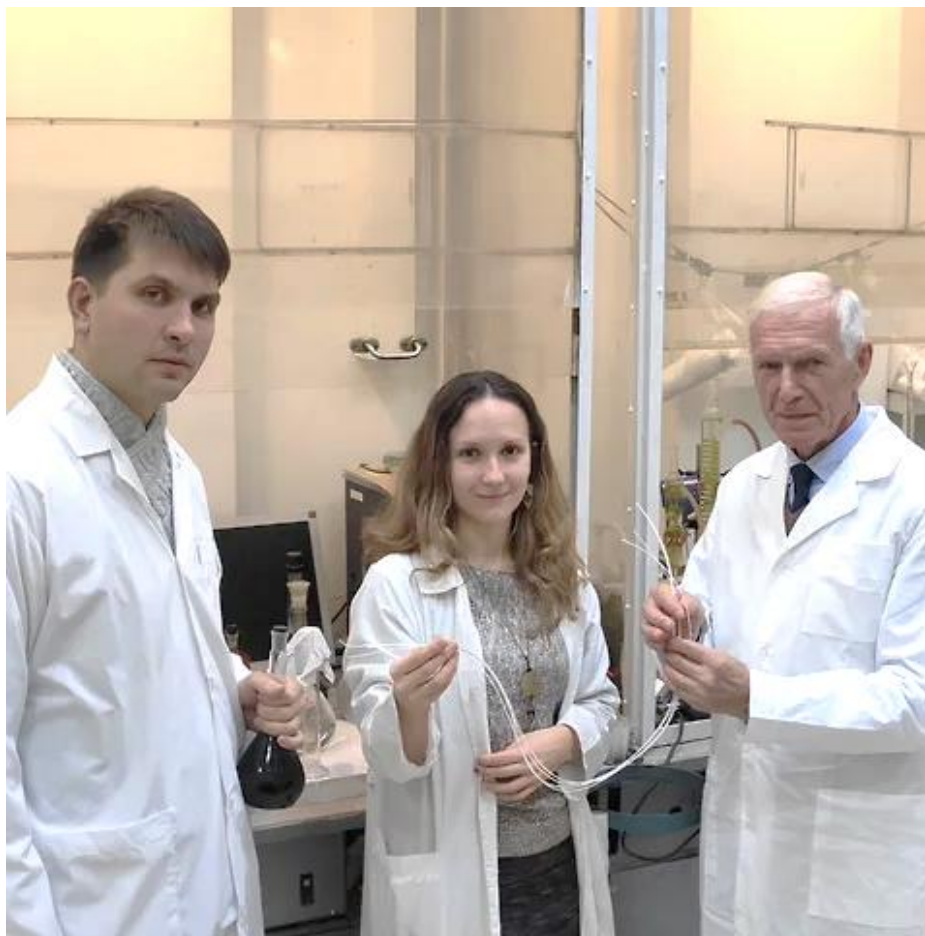

AVK's engineering laboratory is equipped with modern equipment and has a staff of technical experts to develop and analyze the efficiency of products for oil refining and petrochemicals.

Engineering center tasks:

- Development of the most effective formulations
- Control of operational characteristics of products
- Monitoring of quality indicators
- Tracking the effectiveness of products when changing physical, chemical and operational characteristics
- Development of chemical and non-woven materials
- Design and prototyping of industrial solutions
- Implementation of technologies and solutions
- Programs for extending the service life of industrial equipment
- Personnel training

Current projects:

- Development and implementation portable robotic processing system
- Development of construction technology for high resource winter temporary road ice surfaces
- Development and manufacturing of a laser system for surface cleaning without affecting integrity of the protective covering

Additives for fuels and lubricants



- The high quality of our products is the result of 15 years of work of the department responsible for the development, production and distribution of additives for fuels and lubricants.
- Employees of the department have many years of experience in leading international chemical companies BASF and Clariant in the departments of specialty chemicals for fuels and lubricants.
- Production site capacity is 18 000 t/y. Production area is 1 263 sq m. For the first half of 2023 was supplied 13 600 tons of products



Range of additives for fuels



- Pour point depressant and dispersant additives; depressant for heavy and residual fuels; polymer concentrate DDP.
- Antiwear additives for diesel fuels.
- Multifunctional additive packages for motor gasolines and diesel fuels.
- Cetane-increasing additive for diesel fuels.
- Antistatic additives.

Technical service



The technical service team supports current supplies:

- Collection of base fuel on a permanent basis to monitor changes in composition and select or modification the product accordance with the Customer's requirements
- Providing timely technical support in emergency situations/incidents at production facilities
- Departure of employees from JSC "AVK" as required by the Customer.
- Development of new formulations and optimization of existing recipes.
- Monitoring the effectiveness of additives and adjusting dosages during fuel production.
- Exclusion of antagonistic effects of additives when used in combination.

Catalysts and adsorbents for oil refining process



Knowledge of the needs of Russian refineries and the capabilities of Russian and Chinese manufacturers allows our company to select reliable, efficient and profitable catalytic solutions for oil refining processes.

The main products of the division are:

- Catalysts for catalytic cracking
- Catalysts for hydrofining and hydrocracking
- Catalysts for catalytic reforming
- Catalysts for sulfur production and tail gas treatment
- Catalysts for sulfuric acid production (WSA)
- Catalysts for hydrogen production processes
- Adsorbents for the purification and drying of hydrocarbon gases and petroleum products
- Short-cycle adsorption adsorbents
- Inert materials

Catalysts and adsorbents for petrochemical processes



An extensive partner network in Russia, the Near and Far Abroad allows the division's employees to select the most effective and cost-effective solutions for clients, paying special attention to the characteristics of the final products.

The main products of the division are:

- Polymerization catalysts
- Hydrogenation catalysts
- Oxidation catalysts
- Solutions and adsorbents for the fine purification of nitrogen, hydrogen, butene-1, hexene-1, and olefins
- Solutions and adsorbents for the fine purification of monomers

The volume of catalyst supplies in 2023 amounted to 3,100 tons.

The volume of adsorbent supplies in 2023 amounted to 500 tons.

Catalysts and adsorbents: Technical Service

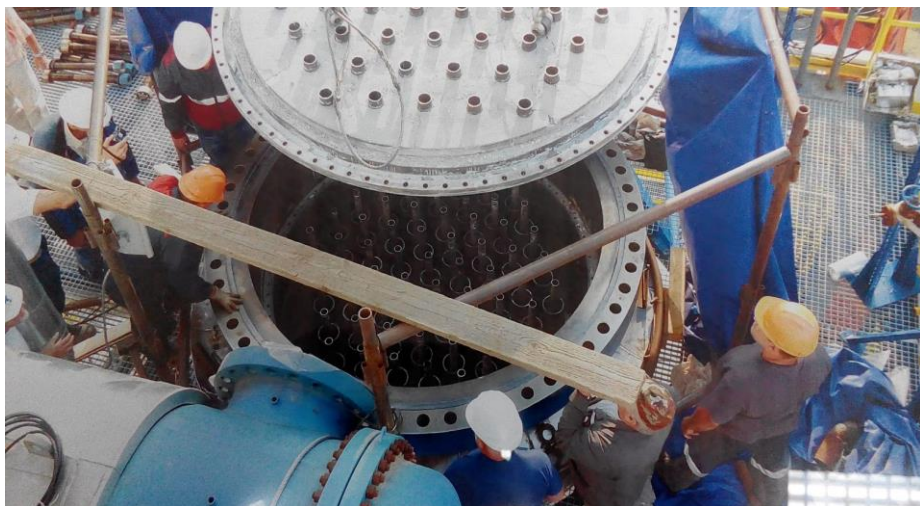

Our technical service team is trained by the product manufacturers and provides the whole cycle of technical support of the supplied products:

- Selection of analogs of Western catalysts and adsorbents, including assistance in laboratory testing of catalyst and adsorbent samples on the customer's raw materials.
- Support of loading, activation and commissioning of catalytic systems.
- Monitoring of catalyst and adsorbent performance.
- Assistance in optimization and troubleshooting of catalysts and adsorbents (if necessary).
- Sample analysis and recommendations on the feasibility of catalyst regeneration and reuse.

Reagents



Specialists of the reagents department pay significant attention to the development and implementation of modern chemical reagents that increase the efficiency of oil extraction and refining

Main products of the department:

- Packages of reagent for chemical-technical protection of primary oil processing equipment from corrosion;
- Reagents for protecting equipment in secondary oil refining processes;
- Packages of reagents for reducing coke formation for tar visbreaking units;
- Reagents for processing industrial water;
- Adaptive gel for increasing oil recovery of wells and limiting water inflow.

The priority direction of our company is engineering and service support of supplied reagents: 24/7 technical support, commissioning, quarterly and annual reports, personnel training, optimization and other services.

The reagents are used at most large factories in Russia and the CIS countries.

Modular oil sludge disposal unit



Advantages of oil sludge recycling unit of JSC «AVK» :

- The installation is supplied in a modular design, with only assembly and connection to utilities required on-site.
- The installation is suitable for processing various types of sludges.
- There are no vessels operating under pressure.
- The process operates at a low temperature (below 100°C).
- As a result of points 3 and 4, there are low operating and capital costs.

No	Industrial implementations	Capacity
1	Sinopec Anqing Refinery	10 ton per day
2	Sinopec Nanhua Refinery	15 ton per day
3	Sinopec Fushun Refinery	5 ton per day
4	Zhejiang Xinnong Chemical Refinery	15 ton per day
5	Hangzhou Jihua Jiangdong Chemical Refinery	30 ton per day

Polymer Additives

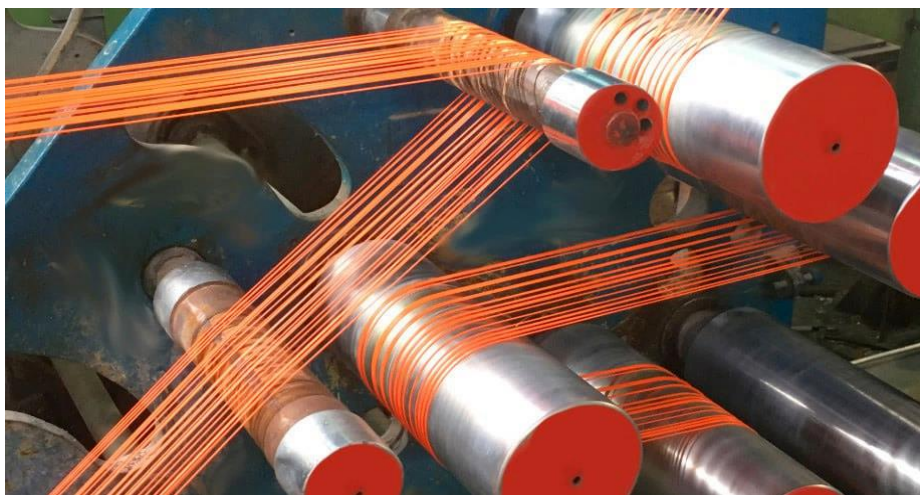

The Polymer additives division has many years of experience in implementation and supply of various additives for polymer production both for up-stream producers of basic polymers and rubbers and for processors. The accumulated experience and competencies allow us to select additives for solving various technological tasks, both as individual components and as customer blends or super concentrates.

Excellent knowledge of the markets of raw materials producers and consumers allows to carry out fast and professional selection of analogs of raw materials of the concerns that left Russia (BASF, CRODA, SONGWON, Nouryon, etc.).

The main products of the division are:

- Stabilizers/antioxidants (phenolic, phosphite, thioethers).
- Customer-specific blend
- Peroxides/polymerization initiators
- Co-catalysts/aluminum alkyls (TEAL, TNHAL, DEAC, EASCH, DEAL, TIBAL)
- Donors for polymerization
- Metal stearates
- Hexene-1
- Hexane
- Isopentane
- Nucleators
- Antistatics
- Anti-block/slip additives
- Bleaching agents for polymers
- Additives for synthetic fiber production
- Hydrotalcite/halogen neutralizer

Solutions for synthesis gas, ammonia and methanol synthesis



Expertise, knowledge and understanding of the market specifics, availability of a full package of products for the industry are the foundations that allow us to offer our clients/partners the most technologically advanced and effective solutions.

The main products of the division are:

- Hydrogenation catalyst
- Catalysts for sulfur and chlorine removal
- Pre-reforming catalysts Reforming catalysts (primary, secondary)
- Low-temperature CO conversion catalyst (LTC)
- Medium-temperature CO conversion catalyst (MTC)
- Methanation catalyst
- Ammonia synthesis catalysts
- Methanol synthesis catalyst

Our technical service team regularly undergoes training with product manufacturers and is ready to provide the necessary technical support:

- Selection of analogues of Western catalysts
- Supervision of catalyst loading
- Support for the launch of catalytic systems
- Monitoring the operation of catalytic and adsorption systems
- Analysis and recommendations on the feasibility of further use of catalysts

Technological equipment for petrochemical and refining industry



Our company has established itself as a reliable supplier of catalysts, adsorbents, additives and other chemical reagents for the oil and gas refining and petrochemical industry.

Today we are ready to offer you our supply services:

- reactors, columns and internal devices;
- heat-exchange equipment;
- pressure vessels and apparatus;
- pumping and compression equipment;
- valves and shut-off and regulating fittings.
- Spare parts for turbines and compressors of foreign production

(Dresser Rand, Elliott, Cooper compression, Coppus, Siemens и т.д.).

- Spare parts (including original) for pumps Grundfos, DAB, Willo, lowara, Pedrollo, Sundyne.

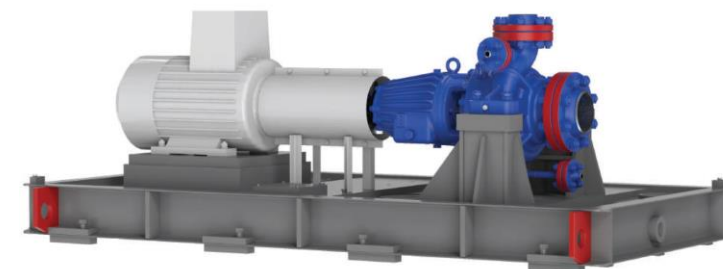
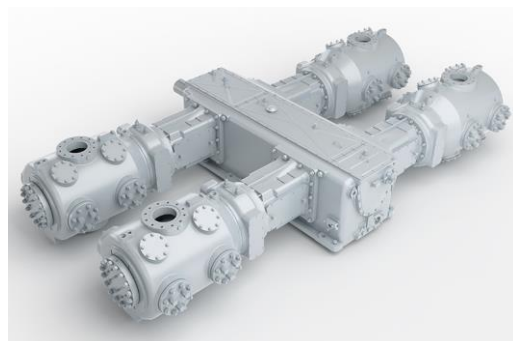

Industrial equipment

In the context of the sanctions regime, the problem of supplying devices and spare details is particularly acute, which is being successfully resolved by our technical experts from the industrial equipment division.

In addition to equipment supplies, the main tasks of the division are::

- Engineering
- Reverse engineering
- Preparation of working documentation
- Design of details, assemblies
- Design and programming of microcontrollers, electrical circuits
- Development of centralized industrial automation systems
- Development of multifunctional robotic platforms for industrial applications

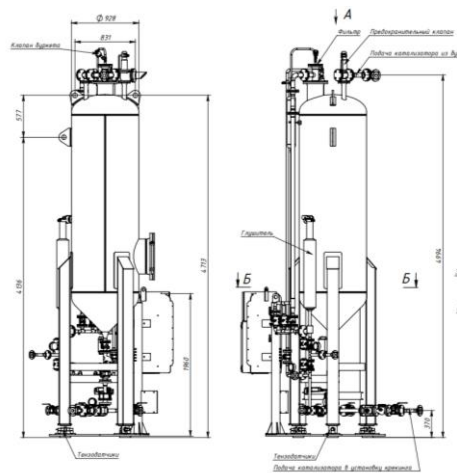
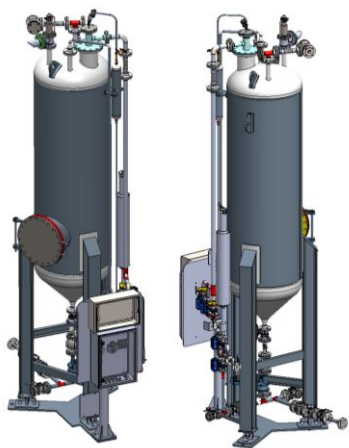
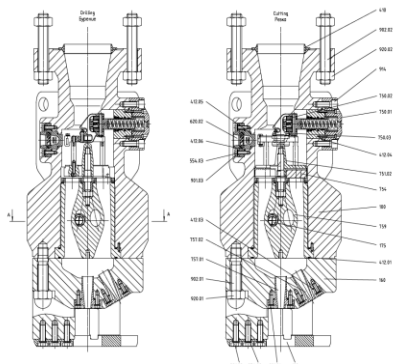

Laboratory equipment

The laboratory equipment division specialists help clients with the search for components for engineering and testing equipment, full technical equipment of laboratories, technical support, service maintenance, repair and provision of spare details and consumable equipment for oil industry enterprises.

The main types of supplied equipment are:

- General laboratory equipment (water and sand baths, flask heaters, aqua-distillers, laboratory furniture, samplers, extractors, etc.).
- Analyzers of oil and oil products (elemental analyzers, chromatographs, spectrophotometers, colorimeters, density meters, moisture meters, viscometers, gas analyzers, etc.).
- Testing equipment (temperature control equipment, testing of materials, cements and drilling muds, determination of flash point, low-temperature properties of fuels and oil products, determination of fractional composition, etc.)
- Equipment for analyzing core properties (core testing, sawing of samples)



| Our clients



A full list of clients and a project reference list can be provided upon request.

Contacts

Head office of AVK JSC

Address:

123112, Russian Federation, Moscow, Moscow City - Federation Tower East, Presnenskaya Embankment, 12

Website: <https://avkavk.ru>

E-mail: info@avkavk.ru

Tel: +7 495 540 59 02

